

STERLING

Pearl 4 Wheel Scooter



Owner's Manual



ENGLISH



Use

Class A Scooters are compact and often portable. They will be manoeuvrable but not necessarily capable of outdoor obstacles.

They are portable in design and can be dismantled into smaller pieces for storage and/or transportation in the boot of a vehicle.

They are intended for use in the home, office, public places and similar locations where there are pavements, pedestrian paths or floors that have hard and firm surfaces. The safe limit for slopes and obstacles shall be observed.

They are intended for a user who has difficulty in walking or limited mobility and is for their own personal use.

The maximum user weight limit, including clothing, is marked on the serial number label, which is affixed to the seat post or rear frame.

Warranty can only be taken on if the product is used under the specified conditions and for the intended purposes.

No unauthorised modifications should be made to the Scooter. Only approved parts and accessories shall be fitted.

Area of application

The electrical power, simple steering and automatic braking make the Scooter suitable for people who have limited mobility due to, for example:

- Joint pain and/or stiffness due for example to Arthritis or Rheumatism
- Difficulty breathing due to respiratory or heart conditions
- Amputees
- Difficulty walking due to stroke

When considering provision, note should be taken of the users the body size, weight, physical and psychological constitution, living conditions and environment.

Contents

| | |
|--|---------------------|
| Introduction | page 1 |
| Guarantee | page 2 |
| How to use this manual | page 3 |
| General warnings | page 4 - 8 |
| EMC (EMI) warnings | page 9 - 10 |
| Features | page 11 |
| Safety warnings & user guidance | page 12 - 17 |
| Tiller control functions | page 18 - 19 |
| Operating your scooter | page 20 - 22 |
| Guidance for safe operation & use | page 23 - 24 |
| Batteries & charging | page 25 - 29 |
| Routine maintenance | page 30 |
| Service history | page 31 |
| Specifications | page 32 |
| Troubleshooting | page 33 |

Introduction

Thank you for choosing a Sunrise Medical scooter.



Before using your scooter please **read this manual carefully**. It will provide you with all the information you will require, however, if you have any queries about the use, maintenance or safety of your scooter please contact your local Sunrise Medical Service Agent. If you have any other questions please write to the address below.

This scooter is designed for comfort, safety and durability and has been exhaustively researched and tested by our experts.

The scooter is classified as a category A vehicle under the European Wheelchair Standard EN 12184.

It is intended for the use of people of all ages who may have difficulty walking distances or for periods of time. It is ideal for indoor and outdoor use and suitable for users up to 136kg (300lbs) in weight. Please see specifications. Differing user weights can cause performance variation. Maximum user weight tested using 136kg test dummy.

The scooter is designed to be driven on footpaths and to cross roads and therefore should not be driven through mud, water, snow, sand, loose gravel or any other unsound surfaces.

It has been manufactured to comply with the requirements of the Medical Device Directive 93/42/EEC / 2007/47/EEC, the radio interference requirements of EEC Directive 89/336/EEC and the battery charger requirements of EEC Directive 73/23/EEC and 89/336/EEC.



Electro Magnetic fields, such as those emitted by shop alarms may be disturbed by use of the Scooter. The function of the scooter may also be disturbed by Electro Magnetic fields emitted by shop alarms.

Sunrise Medical is dedicated to providing products of exacting quality which conform fully and reliably to the requirements of their intended use. We are BS/EN ISO 9001 accredited which is the internationally recognised standard for quality management systems. This approval ensures we provide quality in all areas of our business from development through to final delivery. Should you require any further assistance then please contact your local dealer.

CUSTOMER SERVICES
SUNRISE MEDICAL LIMITED
SUNRISE BUSINESS PARK
HIGH STREET WOLLASTON
WEST MIDLANDS DY8 4PS
ENGLAND

International Telephone +44 1384 44 66 88 Fax +44 1384 44 66 99

eMail: sunmail@sunmed.co.uk

Guarantee

Your guarantee

The guarantee form is supplied with this manual, please fill in the relevant details to register and activate your warranty.

THIS IN NO WAY AFFECTS YOUR STATUTORY RIGHTS.

Warranty conditions

- 1 The repair or replacement will be carried out by an authorised Sunrise Medical Dealer/Service Agent.
- 2 To apply the warranty conditions should your scooter require attention under these arrangements, notify the designated Sunrise Medical Service Agent immediately giving full information about the nature of the difficulty. Should you be operating the scooter away from the locality of the designated Sunrise Medical Service Agent work under the "Warranty Conditions" will be carried out by any other service agent designated by the manufacturer.
- 3 Should any part of the scooter require repair or replacement as a result of a specific manufacturing or material defect within two years from the date on which the possession of the scooter was transferred to the original purchaser, and subject to it remaining within that ownership, the part or parts will be repaired or replaced completely free of charge if returned to the authorised Service Agent.
Note: This guarantee is not transferable.
- 4 Any repaired or replaced part will benefit from these arrangements for the balance of the warranty period applicable to the scooter.
- 5 Parts replaced after the original warranty has expired are covered for a further three months.
- 6 Items of a consumable nature will not generally be covered during the normal warranty period unless such items have clearly suffered undue wear as a direct result of an original manufacturing defect. These items include amongst others upholstery, tyres, inner tubes, batteries and other similar parts.

- 7 The above warranty conditions apply to all, scooter parts, for models purchased at full retail price.
- 8 Under normal circumstances, no responsibility will be accepted where the scooter has required repair or replacement as a direct result of:-
 - (i) The scooter or part not having been maintained in accordance with the manufacturer's recommendations, where such exist. Or failing to use only the specified original equipment parts.
 - (ii) The scooter or part having been damaged by neglect, accident or improper use.
 - (iii) The scooter or part having been altered from the manufacturer's specifications, or repairs having been attempted prior to the Service Agent being notified.

Please keep a note of your local Service Agent's address and telephone number in the space provided. In the event of a breakdown, contact them and try to give all relevant details so they can help you quickly.

The scooter shown and described in this manual may not be exactly the same in every detail as your own model. However, all instructions are still entirely relevant, irrespective of detail differences.

The manufacturer reserves the right to alter without notice any weights, measurements, or other technical data shown in this manual. All figures, measurements, and capacities shown in this manual are approximate, and do not constitute specifications.

Your local service agent:

Your local service agent:



Sunrise Medical Limited

Sunrise Business Park, High Street, Wollaston, West Midlands
DY8 4PS England

Tel 01384 44 66 88 Fax 01384 44 66 99

E-mail: sunmail@sunmed.co.uk

www.sunrisemedical.co.uk

Please remember to fill in and post the guarantee registration card enclosed with this manual. **Sunrise Medical Limited** recommend that you do not undertake maintenance tasks other than those explained in this manual. Your local authorised Sunrise Medical service agent is fully trained by Sunrise Medical to carry out detailed maintenance as and when required. **Use only genuine Sunrise Medical replacement parts.**



How to use this manual

We at Sunrise Medical want you to get the best out of your scooter. This Owner's Manual will familiarise you with the scooter and its features. It contains guidance on everyday usage and general care in addition to information on the high quality standards which we adhere to and details about the warranty.

Your scooter will reach you in excellent condition having been personally inspected before leaving our premises. By following the guidelines in this manual, your scooter will maintain its first class condition and give you years of complete reliability and satisfaction.

WARNINGS

DO NOT OPERATE THE SCOOTER BEFORE READING AND UNDERSTANDING THIS INSTRUCTION MANUAL.

IF YOU ARE IN DOUBT ABOUT THE MEANING OF THESE INSTRUCTIONS, OR ANY OF THE CAUTIONS AND WARNINGS, PLEASE CONSULT YOUR HEALTHCARE PROFESSIONAL, DEALER OR RELEVANT TECHNICAL PERSONNEL.

FAILURE TO FULLY UNDERSTAND THE SCOOTER OPERATION MAY RESULT IN AN UNEXPECTED RESPONSE FROM THE EQUIPMENT WHICH CAN IN TURN LEAD TO POSSIBLE INJURY OR DAMAGE.

NOTES

Warning and Caution notices used in this manual, apply to hazards and unsafe practices that could result in personal injury or damage to property.

WARNING

Sunrise Medical supply an extensive range of mobility scooters to meet the varying needs of individual users. It is the responsibility of the individual user and their healthcare advisor qualified in making such choices, to decide which scooter is suitable for the user's intended purpose.

With regards to restraints, seat positioning straps, posture correction or other positional aids and accessories, it is the obligation of the qualified healthcare professional in conjunction with the dealer to ensure the suitability of such equipment for the safe operation of the scooter.

Serious injury can occur in the event of a fall from a mobility scooter.

Sunrise Medical **DO NOT RECOMMEND** that a scooter user is transported in any type of vehicle when seated in the scooter.

At this time, there are no approved Tie-down Systems for the transportation of a user in ANY moving vehicle whilst seated on a scooter.

It is the opinion of Sunrise Medical that users of mobility scooters should be transferred into the appropriate vehicle seating system and use should be made of the restraints available to the auto industry.

Sunrise Medical **DO NOT RECOMMEND** any mobility scooter tie-down system at this time.

GENERAL WARNINGS

PERSONAL & OPERATIONAL GUIDELINES

Drive profiles should only be adjusted by healthcare professionals and approved agents/dealers, who are totally conversant with the process. They must also fully understand the user's capabilities and the user's ability to operate the scooter safely.

Incorrect settings may cause injury or damage to the user, bystanders, the scooter and/or nearby property.

To determine personal mobility limitations, practice combinations of bending, reaching, mount and dismount techniques, whilst in the presence of a healthcare professional. Practice the above techniques **BEFORE** actively using the scooter.

For users with balance problems, practice the above techniques with the aid of an assistant, in the presence of a healthcare professional.

DO NOT attempt to pick up objects that cause you to shift your weight in the seat or require you to bend excessively in any direction. Such action may result in the scooter tipping over or in injury to the person or both.

DO NOT use an escalator to move the mobility scooter between floors as serious bodily injury could arise from such actions.

DO NOT drive on the road, dual carriageways or motorways.

DO NOT drive up, down or across inclines that have water, ice, oil or any other slippery substance on the surface. Failure to note the above conditions could cause loss of control.

DO NOT attempt to drive over kerbs or obstacles, (accept in accordance with kerb climbing instructions where applicable). Disregarding this warning could cause the mobility scooter to tip resulting in possible bodily harm.

DO NOT make sharp turns in forward or reverse at high speeds.

DO NOT lift the mobility scooter by its Tiller, Seat, Body Panels or by any detachable assemblies. Always disassemble the scooter into its stowable parts and then lift each assembly one at a time.

GENERAL WARNINGS

PERSONAL & OPERATIONAL GUIDELINES

DO NOT operate the mobility scooter without first checking that it is safe to do so. Always be aware of your surroundings.

DO NOT attempt to use your mobility scooter without first checking that all wiring harnesses are connected and all detachable parts/assemblies are correctly aligned and firmly fixed in place.

DO NOT use your mobility scooter without the anti-tipper wheels attached.

DO NOT attempt to fit parts, accessories or adapters that are not authorised by Sunrise Medical.

DO NOT mount or dismount your mobility scooter without first switching the scooter OFF. This will ensure that the power is off and the scooter cannot move unexpectedly.

DO NOT leave the power switch turned on whilst the scooter is unattended. Children or inexperienced people may attempt to drive your scooter which may result in damage or personal injury.

DO NOT connect any medical device, such as a ventilator, life support machine etc. to the scooters electrical system. Failure of the equipment may result from such connections.

DO NOT operate your mobility scooter whilst under the influence of alcohol, drugs or prescription medication that may impair judgement.

DO NOT operate your mobility scooter if you feel acutely unwell.

DO NOT operate your mobility scooter if your vision is seriously impaired.

If you have any doubts about health problems affecting your ability to operate the mobility scooter safely, please consult your healthcare professional.

Sunrise Medical specifically disclaims responsibility to all personal injury and property damage that may occur during use which does not comply with the relevant national or local statutes.

GENERAL WARNINGS

PERSONAL & OPERATIONAL GUIDELINES

The rear body panel, (where fitted), is designed to cover the Drive Assembly, Main Controller, Wiring Harness and Electrical Connectors.

Only remove this panel for the following:

1. To connect/disconnect cable plugs.
2. To disassemble the scooter for transport.
3. To remove/install batteries.
4. To adjust the seat height.

DO NOT stand on any of the body panels, only the footboard.

DO NOT stand on the scooter seat.

DO NOT attempt to transfer into or out of the scooter seat without first checking that it is LOCKED into position. Attempting unsafe transfers can result in bodily injury and/or damage.

DO NOT drive your scooter if the seat is not LOCKED in the FORWARD position. The seat must be secured in the FORWARD facing position BEFORE and DURING operation of the scooter. Attempting to operate the scooter with the seat not secured in the front facing position, could result in damage and/or bodily injury.

DO NOT operate the scooter without ensuring that the Tiller is properly adjusted and secured. After making any adjustment to the Tiller position you must check that the Tiller is locked and secured into position BEFORE driving. To check, gently push and pull the Tiller to make sure it is secured.

An unsecured Tiller could result in damage and/or bodily injury.

DO NOT attempt to climb, ascend, or descend ramps greater than 9 degrees, or transverse slopes with a gradient greater than 9 degrees.

When negotiating ramps or inclines, if the throttle lever is released a roll back will occur.

In FORWARD motion the scooter will ROLLBACK approximately 30cms. (1ft), before the brake engages.

In REVERSE motion the scooter will ROLLBACK approximately 90cms. (3ft), before the brake engages.

GENERAL WARNINGS

PERSONAL & OPERATIONAL GUIDELINES

Check that all electrical connections are secure before using your scooter.

DO NOT under any circumstances, disconnect, cut, extend or otherwise modify ANY of the wiring harnesses installed within or connected to your mobility scooter.

DO NOT under any circumstances, disconnect, cut, extend or otherwise modify ANY of the wiring harnesses installed within or connected to your mobility scooter battery charger.

It is important that your mobility scooter battery charger is connected to a properly installed electrical socket with an earthed outlet.

Failure to comply with the above requirements could result in a possible SHOCK HAZARD.

DO NOT use any batteries that are not DEEP CYCLE GEL, AGM or SEALED LEAD-ACID type. Other types of batteries are NOT SUITABLE. Please read battery/battery charger information before installation.

This scooter has been tested to ISO 7176 Part 9, “Rain Test.”

The test provides the scooter user or their attendant, sufficient time to remove the mobility scooter from a rain storm, whilst retaining normal operation of the mobility scooter.

DO NOT operate your mobility scooter during an electrical storm.

DO NOT leave your mobility scooter in a rain storm of any kind.

DO NOT use your mobility scooter in a shower or leave it in a damp bathroom or sauna.

DO NOT leave your mobility scooter in a damp area for any length of time.

DO NOT Jet wash, hose down, or use an automated car-wash on your mobility scooter.

Direct exposure to rain, sea spray or moisture could cause the mobility scooter to malfunction electrically and mechanically and may cause rusting.

Maximum User Weight Limitations.

| | |
|--------------|------------------|
| PEARL | = 136Kg (300lbs) |
| Front basket | = 4.5Kg (10lbs) |

EMC (EMI) WARNINGS

CAUTION: IT IS VERY IMPORTANT THAT YOU READ THIS INFORMATION REGARDING THE POSSIBLE EFFECTS OF ELECTRO MAGNETIC CONTAMINATION, (EMC) ON YOUR MOBILITY SCOOTER. SOMETIMES THIS EFFECT IS ALSO KNOWN AS ELECTRO MAGNETIC INTERFERENCE, (EMI).

EMC, (EMI), FROM RADIO-WAVE SOURCES.

Mobility scooters may be susceptible to EMC, which is interference from electromagnetic energy, (EM), emitted from sources such as radio stations, TV stations, amateur (HAM) radio transmitters, two way radios and mobile phones. The interference, (from radio sources), can cause the mobility scooter to release it's brakes, move by itself, or move in an unintended way. Permanent damage can also be done to the mobility scooters control system.

The intensity of the interfering EM energy can be measured in volts per meter, (V/m.).

Each mobility scooter can resist EMC up to a certain intensity.

This is known as the scooters "immunity level".

The higher the immunity level, the greater the protection.

Current technology offers useful protection of at least 20 V/m. which provides protection from the more common sources of radiated EMC.

There are a number of relatively strong electromagnetic fields present in the everyday environment. Most of these sources are obvious and easy to avoid, others are not so obvious and can be unavoidable.

By following the warnings listed, your risk of exposure to EMC will be minimised.

EMC sources can be broadly classified into three types;

1. Hand-held portable transceivers, (transmitter-receivers with on-board antenna). Examples are Walkie-Talkie, CB Radio, security, emergency services, Mobile phones. Note that some cellular phones can transmit signals while they are switched on but not being used.
2. Medium range mobile transmitters such as those used on emergency services vehicles, taxis etc. These usually have antennas mounted on the outside of the vehicle.

EMC (EMI) WARNINGS

3. Long-range transmitters and transceivers, such as commercial broadcast transmitters, (radio and TV broadcast antenna towers) and amateur (HAM) radios.

Note: *Other types of hand-held devices such as cordless phones, laptop computers, AM/FM radios, TV sets, CD players, cassette players and small appliances, such as electric shavers and hair dryers, are not likely to cause any EMC problems to your mobility scooter.*

Mobility scooter electromagnetic contamination, (EMC).

EM energy rapidly intensifies the closer one moves to the transmitting antenna, the source. Because of this it is possible to bring strong EM fields unintentionally close to your mobility scooter's control system. Mobile hand-held radio type transceivers are of particular concern.

Whilst such devices are in use, it is possible that the EM radiation can affect the mobility scooter's movement and braking.

The following warnings are recommended to help prevent possible interference with your mobility scooter's control system.

1. Do not operate hand-held transceivers, such as CB radio or turn ON cellular phones, whilst your mobility scooter is turned ON.
2. Be aware of nearby radio or television transmitters and try to avoid coming too close to them.
3. If you experience unintended movement or brake release, switch your scooter OFF as soon as it is safe to do so.
4. Adding accessories, components or modifying the mobility scooter, may increase susceptibility to EMC (EMI).

Note: *There is no easy way of assessing the effect of any modification on a scooters EM immunity.*

5. If you experience any EMC (EMI) related incidents, please report them to your dealer, noting if there is a possible source of EM transmission nearby.

Features



Safety warning and user guidance

Getting on to your scooter

1. Ensure that the on-off switch or key switch is turned to the off position.
2. Stand at the side of the scooter, facing forwards.
3. Pull the armrest upwards until vertical.
4. Make sure that the seat is secure, with the backrest upright.
5. Steady yourself with your right hand on the tiller and place your right foot onto the floorboard.
6. Gently lower yourself into the seat.
7. Ensure that both feet are placed firmly on the floorboard of the scooter .
8. Pull the armrest downwards and allow it to gently settle back into position.

Note:

Before operating the scooter check that the tiller is not locked. If locked **release the tiller lock at the bottom of the tiller by moving it central to the tiller.**

Getting off your scooter

1. Bring your scooter to a complete stop.
2. Make sure that the on-off switch or key switch is turned to the off position.
3. Pull the armrest upwards until vertical.
4. Put your left foot on the ground gently steadying yourself.
5. Carefully get out of the seat and stand by the side of your scooter with both feet on the ground.
6. You may leave the armrest in this position or return it to normal.

Safety warning and user guidance

General safety warnings

Safety is important with any vehicle that is power driven. Below are some essential tips to safeguard your use. These are not conclusive and should be read in conjunction with the sections which explain how to adjust, operate and maintain your vehicle.

Always ensure that your scooter is switched off before attempting to mount or dismount.

Do not attempt to operate your scooter whilst standing next to it.

Always ensure that you are able to operate all the controls from a seated position, that the rear view mirror (if fitted) is set correctly and that the seat is securely locked into place.

Attention: Switch on the scooter lights, (if fitted), to make yourself visible when there are low levels of light, day or night.

Do not operate your scooter whilst under the influence of alcohol or drugs, or if you are feeling acutely unwell.

Please observe all relevant rules and regulations pertaining to pedestrians at all times.

Turning corners

Always reduce your speed when turning corners, particularly when travelling downhill.

Disregard of this advice could lead to your scooter tipping over.

Kerb climbing

Do not attempt to mount or dismount kerbs.

Always cross the road with caution taking the safest and most direct route.

Do not attempt to mount or dismount footpaths in reverse.

Hill climbing

Where possible always travel up or down hills or ramps directly facing the slope of the hill.

This scooter has been tested to climb an incline of no more than **8° with a maximum user weight of 136kg/300lbs**. See specifications. Do not attempt to climb inclines in excess of this.

Always reduce your speed to the minimum setting and use extreme caution when reversing down hills.

Do not attempt to drive along with the wheels at different levels, e.g. along the footpath and road simultaneously.

Please note that lap belts must only be obtained and fitted by an authorised Sunrise dealer and used according to the advice of your healthcare professional.

Safety warning and user guidance

Lifting heavy or bulky components

Seat:

1. Lift armrests upwards until vertical (Photo 1).
2. Stand behind seat and fold the backrest down (Photo 2).
3. Hold the seat rotation lever upwards.
4. Carefully remove the seat, keeping your back straight and bending your knees.
5. Place seat at desired location for stowage, keeping back posture straight at all times, bend knees where required.

Batteries:

1. Remove the seat.
2. Remove left battery pack first (Photo 3+4). Then remove the right battery pack. Take note of the instruction on the yellow triangular label.
3. To replace the battery packs install the right battery pack first and then the left. Take note of the instruction on the yellow triangular label (Photo 5).
4. The battery packs must be engaged together before driving (Photo 6).



Safety warning and user guidance

Batteries

Always check the batteries are sufficiently charged before setting off.

Always ensure that your batteries are in good condition and that no leakage has occurred.

Beware, battery fluids are corrosive and care should be taken at all times to avoid contact with it. If it comes into contact with the skin or clothing, wash immediately with soap and water. If it comes into contact with the eye, immediately flood the eye with running cold water for at least 10 minutes and seek medical attention.

Keep batteries upright at all times, especially when transporting your scooter.

Always follow the procedures for battery charging set out in Pages 25 - 29.

Always charge your batteries in a room with good ventilation.

Do not charge your batteries in outdoor conditions.

Do not expose any part of your charger, battery or scooter to direct heat (i.e. Gas fires or naked flame).

Tyres

Your scooter has solid tyres all round. They do not require inflation.

It is good practice to inspect the tyres for damage or wear, regularly.

Emergency Braking

Turning off the power switch whilst moving will switch off the power causing immediate and full braking. This method of stopping is not recommended except in an emergency.

Caution!

Routine use of emergency braking will cause damage to your scooter.

Freewheel mechanism

Caution!

Transporting the scooter along a slope in freewheel mode can be dangerous. Take extra care if this is necessary. Always re-engage the freewheel device after use.

Never sit on your scooter whilst in freewheel since the scooter will no longer automatically stop.

Safety warning and user guidance

Transportation (De-docking)

When transporting the scooter remove seat and lower the tiller. The battery can be removed and the rear end of scooter dismantled.

Always stow your scooter in the luggage compartment of your vehicle.

The tiller can be locked centrally by pushing up the tiller lock at the bottom of the tiller.

Always ensure your scooter or scooter parts are securely anchored when being transported.

Do not sit on your scooter whilst it is being transported in or on another vehicle.

Do not attempt to carry passengers on your scooter.

Do not attempt to tow another vehicle.

Seat Height Adjustment

The seat post is height-adjustable by firstly removing the battery.

Fold down the armrests, backrest and lift the seat off.

Remove the seat height adjustment pin. Move the seat post to the desired position and re-insert the seat height adjustment pin, (Photo 7).

Replace seat and check that all parts are secure.

Seat Swivel

To make it easy to get on and off of the scooter, the seat can swivel 360° and lock into 4 positions. Simply lift the lever under the seat and rotate the seat round.

Use of mobile phones

Mobile telephones or two way radio devices must not be used while operating the vehicle.

Use of mobile phones or two way radios can cause excessively strong electromagnetic fields. This may interfere with the vehicle's electronic systems.

If mobile phones or mobile radios are required to be used, the vehicle must be brought to a halt and the power turned off before any such device is switched on or used.

If you are in any doubt about your ability to drive the scooter due to any medical condition or treatment, then consult your doctor.

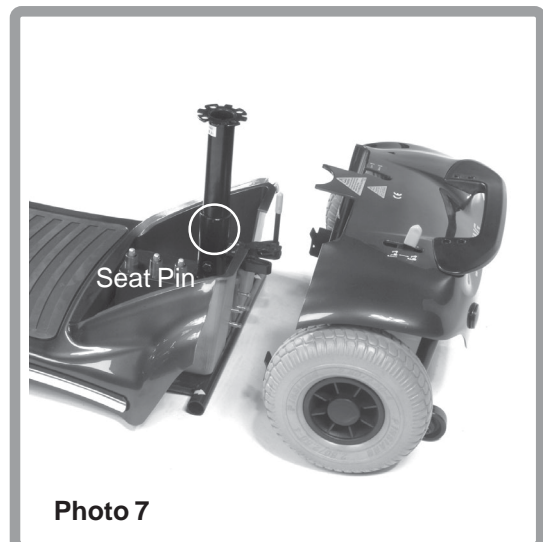

Safety warning and user guidance

Armrest Adjustment

The width of the armrests can be adjusted by loosening the two thumbwheel knobs located under the seat base, moving the armrests to the desired position and re-tightening the thumbwheel knobs.

Tiller Adjustment

The scooter features an adjustable tiller which allows you to lock the tiller in the most comfortable driving position. This feature also lets you fold the tiller down fully, for transportation and stowage.

The tiller release knob is located on the lower right side of the tiller.

1. Support the tiller with your left hand.
2. Turn the large grey tiller knob anti-clockwise to release.
3. Move the tiller to the desired position.
4. Turn the tiller knob clockwise to tighten.

Tiller control functions

Hand Controls

All of the drive controls for the scooter are to be found on the Tiller Control Box (Photo 8).

The Pre-set Speed Knob

Turning this knob to the left, reduces your available maximum speed. Turning it to the right, increases the available maximum speed.

The Battery Gauge

This gives an approximation of battery charge.

The gauge is marked from “E” empty, to “F” full. For extra clarity there is a coloured graduated scale ranging from RED, (E) through YELLOW to GREEN, (F).

As the scooter moves over differing terrain, the Battery Gauge will dip up and down, this is normal. For a more accurate indication, stop the scooter and note the reading.

GREEN indicates ready for use.

YELLOW indicates batteries to be charged as soon as possible.

RED indicates charge batteries immediately.

TIP:

If you find that your battery gauge has gone into the red whilst you are out and about, you can increase the remaining range of your scooter by reducing your maximum available speed, but you **MUST** charge your scooter as soon as you can.

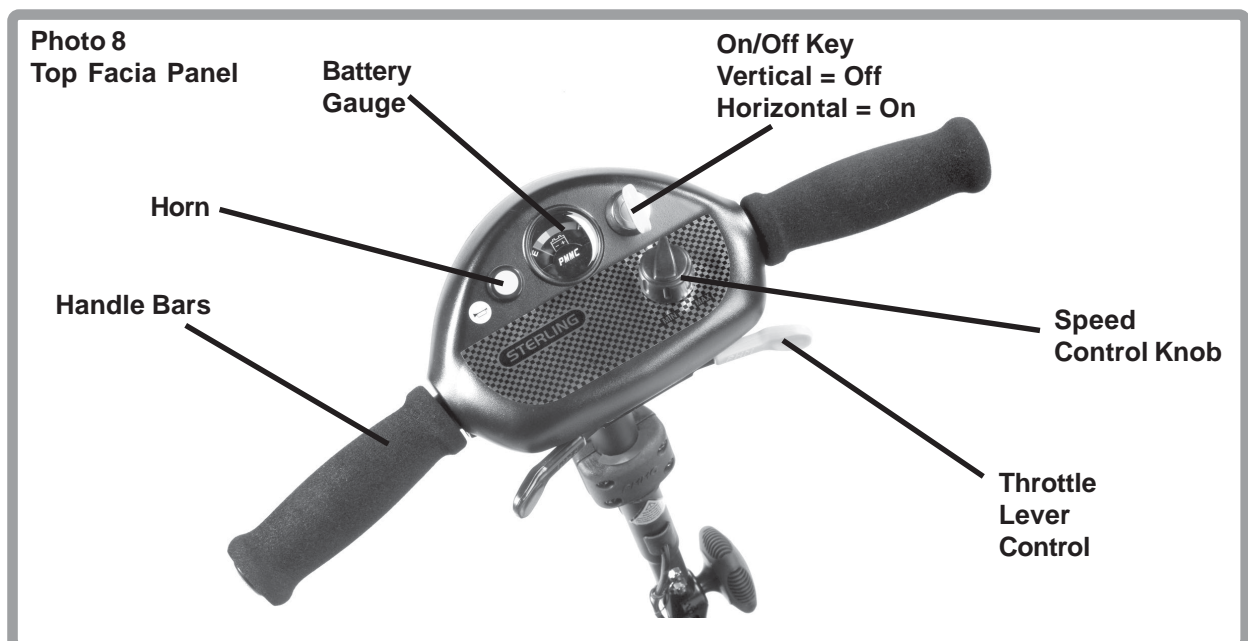

Tiller control functions

Throttle Lever

The throttle lever offers thumb-tip control of your scooter, (Photo 8).

It controls the speed as well as forward and reverse motion.

Pushing the right-hand side of the lever away from you with the right thumb, moves the scooter forwards. Pushing the left-hand side of the lever away from you with your left thumb, moves the scooter in reverse and sounds a reversing beeper. The more you move the lever, the more your speed increases up to its preset maximum. It is possible to operate your scooter using one side of the throttle lever. To do this you must PUSH and PULL on the chosen side of the throttle lever.

Note: *One-hand operation requires careful concentration and is more tiring than normal operation.*

Horn Button

Pressing the yellow Horn button operates an audible buzzer. Use this function to warn pedestrians of your presence when necessary.

On-Off Switch/Key Switch

If your scooter has a key, it is horizontal when in the **on** position (photo 8).

Make sure that this switch is in the OFF position BEFORE getting on or off the scooter.

Switching this switch to OFF whilst driving, will cause the scooter to stop very abruptly. This is not recommended.

To protect battery charge, your scooter is fitted with a sleep mode function. If the key switch is left on without driving for 5 minutes, the battery gauge will show full charge but the scooter will not drive. Simply turn the key off and on again and you are ready to go.

Operating your Scooter

Freewheel mechanism

A freewheel device disengages the power drive to allow manual operation (Photo 9).

The freewheel is selected by operating the lever which is located at the rear of the scooter. Once freewheel has been selected, the electronic drive control system is disabled to prevent driving. This is a safety feature to prevent you driving the scooter with the parking brake disengaged.

To turn off the freewheel and engage the motor, simply push the lever forwards (Photo 9).

Note: Use extreme caution in the freewheel mode, especially on slopes/inclines. Letting go of your scooter whilst it is in freewheel, can cause the scooter to roll unexpectedly. This could cause damage or bodily harm.

Caution!

It is advisable that during the first few sessions of operating your scooter that the area around you is clear of obstacles and pedestrians.

Before operating your scooter, ensure the seat height has been adjusted to your satisfaction, and the tiller angle has been set for optimum safety and comfort.

Please see the “General Warnings”, “Getting on Your Scooter” and “Tiller Adjustment” sections earlier in this handbook.

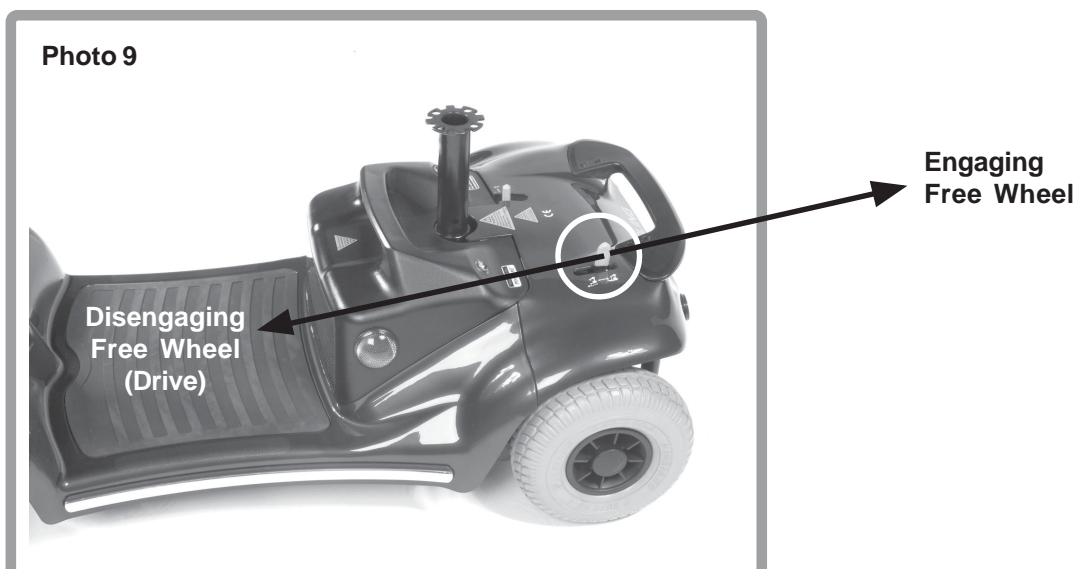

Operating your Scooter

Basic Driving

1. Make sure you are properly seated on the scooter and that the Speed Control knob is turned fully to the left, towards the Min. position..
Note: *Reverse movement of the scooter may not occur when Speed Control Dial is turned fully anti-clockwise and reversing up a slope.*
2. Turn the On-Off switch or key to the On position.
3. On tiller, use the throttle lever as described earlier.
You will gently accelerate. Release and you will gently stop.
Practice these two basic functions until you get used to them.
4. Steering the scooter is easy and logical. Be sure to remember to allow enough clearance when turning corners so that the rear wheels clear any obstacle.
5. Shortcutting a pavement corner can cause the back wheel to go off the pavement, causing problems, if the corner is very rough. Avoid this at all times by steering an exaggerated curve around the obstacle.
6. When steering in a tight spot, such as entering a doorway or when turning around, stop the scooter and then turn the handlebar to where you want to go, then apply power gently. This will make the scooter turn very sharply. It is also recommended that the pre-set speed is set to a slower setting to aid control in tight spots.

Exercise caution when reversing

7. Reversing requires attention.
Left hand push or right hand pull operation of the throttle lever will move the scooter in reverse.
When reversing, always turn the handlebars in the opposite direction to the way you want to go.
The more you pull the throttle lever, the faster you will go.
Reverse speed is 50% slower than forward speed. If the scooter does not move in reverse, carefully turn the speed control knob clockwise until the scooter moves gently backwards.

Operating your Scooter

Braking

To bring the scooter to a standstill simply let go of the throttle control lever. Remember to keep your hands on the handlebars whilst the scooter is braking.

Two types of braking are used.

- (a) Automatic regenerative braking, which slows the scooter to a stop.
- (b) Automatic braking which will operate a couple of seconds after releasing the control lever and holds the scooter in position, even if you are on a hill.

Note: *Automatic braking is not instantaneous and will engage within 1/2 a wheel turn once the scooter has stopped.*

Emergency Braking

In the unlikely event of an unwanted movement of the scooter, switching off the On-Off switch will bring the scooter to a stop.

Though very effective, emergency braking is extremely abrupt and must never be used under normal circumstances.

Letting go of the throttle lever will slow the scooter to a controlled stop.

Switching off

The scooter must always be switched off at the On-Off switch.

When the scooter is stowed or not in use for a long period of time, always switch the battery pack off.

Guidance for safe operation and use

Crossing roads

Your scooter is not capable of mounting and dismounting kerbs and other obstacles. Always use pedestrian crossings or drop downs. Be aware that some drop downs may be entrances to driveways. Use caution if this is the case.

Remember before crossing the road, drive forwards and position the scooter at 90° to the road. Stopping about 30 - 60cm (1 - 2 feet), away from the edge of the footpath. Check that it is clear to cross. Select a medium to high speed setting and when safe to do so, drive across without stopping.

Note: Heavier users will require higher speed settings.

Note: Low speed settings are recommended when travelling down hill, particularly in reverse. Also, reduce your speed when turning corners. The anti-tip devices fitted to the scooter must not be removed

Travelling across slopes

Care should be taken traversing across a slope.

Note: Do not traverse across the face of a slope in excess of 8°. Disregard of this advice could result in your scooter tipping.

Use on the footpath

When using your scooter on the footpath always be aware of pedestrians and situations which might require extra care. For example, young children and pets. Remember, especially when driving in public places, to drive with caution and regard for others at all times. When manoeuvring in confined areas, including shops, ensure the minimum speed is selected. If you leave your scooter outside a shop ensure that it does not obstruct pedestrians or vehicular access, and remember to switch it off for safety.

Guidance for safe operation and use

Hill climbing

Your scooter is designed to travel up or down most reasonable slopes up to 9°, however both hill climbing capability and distance travelled between battery charges will be adversely affected by such things as:

1. The weight of the user.
2. Terrain (e.g. grass or gravel).
3. Steepness of hills.
4. Level of charge and the age of the batteries.
5. Extremes of temperature.
6. Use and weight of accessories.

Transportation

Your scooter may be disassembled quickly and simply for transportation by car:

- (i) Lift off the front basket.
- (ii) Remove the seat, leaving the seat stem in position.
- (iii) Remove the battery packs as shown on page 14
- (iv) Lower the tiller using the adjustment knob, to its lowest setting (Photo 10 and 11).
- (v) The rear section can be de-docked if necessary (Photo 12 Photo 13).

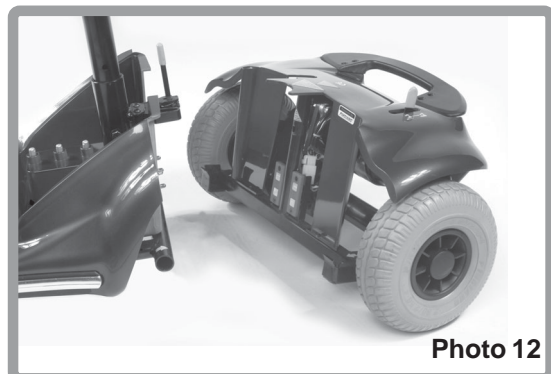
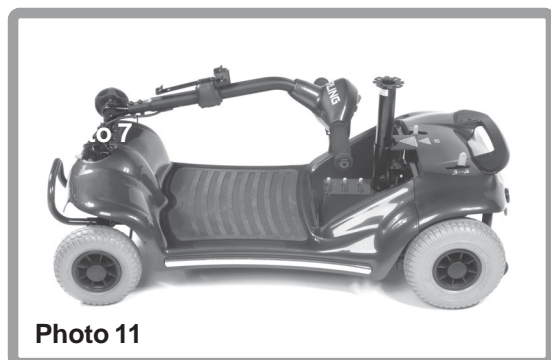

Batteries and charging

General information

Batteries are the power source for almost all of the modern mobility products available today. The design of batteries used in mobility products is significantly different from the batteries used to start a car for example. Car batteries are designed to release a large amount of power over a short period of time, whilst mobility batteries (commonly called deep cycle batteries) release their power, evenly, over a long period of time. Therefore, due to the lower production volumes and increased technological requirements, mobility batteries are typically more expensive. Commonly two 12 volt batteries are used together in a mobility product giving a total voltage of 24 volts. The size of the battery, (e.g. its available power) is expressed in amps per hour (e.g. 10amp/hr). The higher the number, the bigger the battery size, weight and, potentially, the greater the distance you can travel.

Battery pack

Your scooter is fitted with a battery pack that requires no maintenance, other than regular charging.

If the battery pack is physically damaged, please use extreme caution when handling it.

Leaking battery fluids are corrosive and toxic.

In such an event, call your local dealer for assistance

Please do not dispose of batteries in normal waste, always recycle in accordance with local laws.

Maintenance free

This is the type of battery used in the battery pack. It uses GEL electrolyte which is totally sealed within the battery's outer case. As the name implies, no maintenance is required other than regular charging. As the battery case is sealed, you can safely transport this type of battery without fear of acid spilling.

Furthermore, they are approved for transportation on aircraft.

It is recommended that the batteries are always stored upright.

Only use batteries supplied by an authorised Sunrise Dealer.

Battery care

Below is set out a battery care plan for maintenance free batteries. This has been agreed between Sunrise Medical and the battery manufacturers to enable you to get the best out of your batteries. If a different care plan is followed, this may result in lower than expected performance from your mobility vehicle.

Note: Do not expose any part of the battery to direct heat and when charging always place on a hard surface in a room with good ventilation. You should not charge the batteries in outdoor conditions.

Do not smoke when in the vicinity of charging batteries. Exclude all naked flames from the area.

Batteries and charging

Battery pack care plan

1. Only use the approved battery charger compatible with the vehicle to be charged.
2. Charge your batteries every night, regardless of the amount of use your mobility device has had during the day.
3. Do not interrupt the charging cycle.
4. If your mobility device is not required for use, it should remain connected to the charger for a maximum of 12 hours. This will not damage the batteries, so long as the mains socket/plug is left switched on.
Do not leave the charger still connected to the batteries, when the mains has been switched off. This will eventually deplete the battery charge.
5. If you leave your vehicle for an extended period (more than 5 days) first charge your batteries for 12 hours, then remove charger lead and ensure the scooter is switched off.
6. Failure to allow for recharge will damage the batteries and can lead to shortened distances and permanent failure.

7. Do not top up the charge of your batteries during the day. Wait until the evening for a full overnight charge.

Caution!

Always remember to remove the plug from your scooter after charging to prevent driving away whilst attached.

The scooter can not be operated when being charged.

8. The battery pack needs to be checked regularly for signs of damage. If any damage is apparent, contact your local mobility dealer.

Caution!

Take care not to short circuit the battery terminals. When using metal tools, exercise great care. Remove all conductive jewellery (e.g. watches, necklaces etc.) before handling exposed batteries.

9. Following all the eight points above should result in a healthier battery, greater range for the vehicle user and a longer life for your batteries.

Batteries and charging

The range of your vehicle

Most manufacturers of mobility products state the range of their vehicles either in the sales literature or within the Owners Manual.

The range stated sometimes differs from manufacturer to manufacturer even though the battery size is the same. Sunrise Medical measure the range of their vehicles in a consistent and uniform manner, but variances still occur due to motor efficiencies and overall product load weight.

The range figures are calculated to I.S.O. Standard 7176, Part 4: Scooter Energy Consumption Theoretical Range.

This test is carried out in controlled conditions with new, fully charged batteries, on a level test surface and a user weight of 85kg. The range figures stated should be seen as a theoretical maximum and could be reduced if any single, or combination, of the following circumstances occur:

1. User weight heavier than 85kg.
2. Batteries whose age and condition are less than perfect.
3. The terrain is difficult or unsuitable e.g. very hilly, sloping, muddy ground, gravel, grass, snow and ice.
4. The vehicle climbs ramps regularly.
5. The ambient temperature is very hot or very cold.
6. Damage occurring to one or more tyres.
7. Lots of start/stop driving.
8. Also thick pile carpets within the home can affect range.

All this technical information may seem complicated and a little daunting, but please remember, that the battery sizes available on your scooter should give sufficient range to cope with the majority of customer's lifestyles.

Batteries and charging

Off Board Battery Charger

Your scooter is supplied with an off-board charging facility. Please note that only chargers with a capacity of minimum 1.5 Amp and maximum 3 Amp supplied by your local authorised Sunrise dealer should be used. Your battery pack can be charged on or off the scooter. To remove the battery pack please refer to, "Safety Warnings & User Guidance, Batteries".

1. Switch your scooter off at the tiller power switch.
2. Remove the battery pack from the scooter if required.
3. Swivel the charge connector cover located on the battery pack and connect charger.
4. Ensure that the charger plug is dry and intact before connecting it to the mains and switching it on.
5. A reset button is located on the battery pack to the left-hand side looking from the rear of the scooter. Please check that the button is pressed in.

Important safety warnings:

Do not expose any part of the battery pack to direct heat (i.e. naked flame, gas fire).

Do not allow the batteries to freeze.

When charging always place on a hard surface in a room with good ventilation. You should not charge your batteries in outdoor conditions.

Always use Sunrise recommended batteries from your local authorised dealer. The off-board charger must be kept dry in temperatures between -25°C and 40°C and not be subjected to mechanical shock/damage.

In all cases, the charger must only be repaired by a Sunrise authorised dealer.

Fuses

There is a reset button on the left-hand side of the battery pack, looking from the rear of the scooter, (Photo 14). If a fault occurs, the button will pop out. Switch the scooter and battery pack off, press the button in and switch the battery pack on first and then the scooter.

There is also a fuse fitted in the mains plug of the battery charger, if this blows, switch off at the mains and replace the blown fuse with a new fuse of the same value.

Batteries and charging

Off Board Battery Charger

The **3 Amp**, off-board battery charger has a status indicator which tells you when your battery pack is fully charged, (Photo 14).

There are three (3) possible indications:

1. **OFF = Not connected / fault.**
2. **RED = Power On.**
3. **GREEN = Fully charged.**
4. **FLASHING GREEN = Charging**



Photo 14

Please note that the scooter has a safety circuit to prevent it from being driven off during charging. If your scooter fails to respond to normal control after a charging period, please check that the battery charger has been completely disconnected from the scooter.

New batteries must always be charged for 12 hours BEFORE first use.

To charge off board ensure that the battery packs are connected together (Photo 15).

On Board Battery Charger

To charge on board ensure that the battery packs are connected together (Photo 16+17)

! WARNING !

NO SMOKING OR NAKED FLAMES WHEN CHARGING BATTERIES.

DON'T TOUCH BATTERY PACK TERMINALS WITH METAL OBJECTS.

REMOVE METALLIC JEWELLERY WHEN WORKING WITH BATTERIES.

WEAR GLOVES AND GOGGLES IF MOVING LEAKING BATTERIES.

REPLACE DAMAGED OR LEAKING BATTERIES IMMEDIATELY.

ONLY USE APPROVED REPLACEMENT BATTERIES.



Photo 15



Photo 16



Photo 17



Routine maintenance

The following table gives an indication as to when routine maintenance checks should be made.

| <i>There is no service manual available. Maintenance, fault finding and servicing should be carried out by an authorised Sunrise dealer unless otherwise indicated.</i> | | | | | | |
|--|-----------------------|-----------------------|---------|-----------------------|-------------|-----------------------|
| The checks below can be carried out by the user | Daily | Weekly | Monthly | Quarterly | Six Monthly | Annually |
| Battery charge check Look at battery charge indicator on tiller before use to ensure batteries are fully charged. | <input type="radio"/> | | | | | |
| Inspection of connectors (Fig. C) Remove rear panel (where fitted), and ensure all connectors are secure. | | <input type="radio"/> | | | | |
| Wipe over with a damp cloth Use only a damp soft cloth and mild detergent on panels, tiller and seat. | | <input type="radio"/> | | | | |
| Check tyres Each tyre should be free of debris, oil, deep cuts or distortion. | | <input type="radio"/> | | | | |
| Long overnight battery charge Please ensure that the batteries are charged for a minimum of 8 hours. | <input type="radio"/> | | | | | |
| Check tyres for wear (See Fig. A and Fig. B) Look at the tyres to ensure that the tread is visible and continuous. | | | | <input type="radio"/> | | |
| The checks below must be carried out by an authorised Sunrise dealer | | | | | | |
| Seat swivel, seat slide (where fitted) | | | | | | <input type="radio"/> |
| Inspection of wiring for chafing and wear | | | | | | <input type="radio"/> |
| Battery pack terminals Clean and protect with petroleum jelly. | | | | | | <input type="radio"/> |
| Ensure parking brake (where fitted) is correctly adjusted | | | | | | <input type="radio"/> |
| Check stabiliser wheels for wear | | | | | | <input type="radio"/> |
| Inspect motor brushes | | | | | | <input type="radio"/> |
| Full service by dealer | | | | | | <input type="radio"/> |

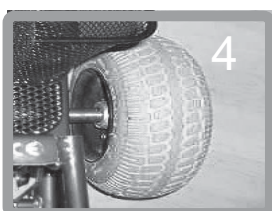

Fig. A

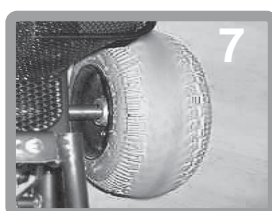

Fig. B



Fig. C

Storage

When storing your scooter for long periods (in excess of one week), charge batteries for 12 hours and then lift off the battery pack to minimise battery discharge.

Electronic faults

Do not attempt to investigate faults in the control box, the control pod or charger as the design and set up of the electronics is of a safety critical nature.

Spare parts are available from authorised Sunrise Dealers.

Wheels

Note: Wheels should only be removed and refitted by an authorised dealer.

Service history

This section is designed to assist you in keeping a record of any service and repairs to your scooter. Should you decide to sell or exchange your vehicle in the future, this will prove most helpful to you. Your Service Agent will also benefit from a documented record and this manual should accompany the scooter when service or repair work is carried out. The Service Agent will complete this section and return the manual to you.

| | | | | | | | | | |
|---------------------------|----------|----------|----------|----------|-------------------------------------|----------|----------|----------|----------|
| Customer Name. _____ | | | | | Date scooter purchased _____ | | | | |
| Address _____ | | | | | Model _____ | | | | |
| _____ | | | | | Colour _____ | | | | |
| Postcode _____ | | | | | Serial No. _____ | | | | |
| YEAR | 1 | 2 | 3 | 4 | YEAR | 1 | 2 | 3 | 4 |
| Service dates | | | | | Service dates | | | | |
| Controller | | | | | Upholstery | | | | |
| On/off switch | | | | | Seat | | | | |
| Output plug | | | | | Back | | | | |
| Operation | | | | | Armrests | | | | |
| Dynamic braking | | | | | Electrics | | | | |
| Programmable settings | | | | | Condition of loom | | | | |
| Batteries | | | | | Connections | | | | |
| Levels | | | | | Lights (where fitted) | | | | |
| Connections | | | | | Test run | | | | |
| Discharge test | | | | | Forwards | | | | |
| Wheels/tyres | | | | | Reverse | | | | |
| Wear | | | | | Emergency stop | | | | |
| Pressure | | | | | Left turn | | | | |
| Bearings | | | | | Right turn | | | | |
| Wheel nuts | | | | | Up/down slope | | | | |
| Motors | | | | | Over obstacle | | | | |
| Wiring | | | | | Parking brake (where fitted) | | | | |
| Noise | | | | | List items repaired/adjusted | | | | |
| Connections | | | | | | | | | |
| Brake | | | | | | | | | |
| Brushes | | | | | | | | | |
| Chassis | | | | | | | | | |
| Condition | | | | | | | | | |
| Steering | | | | | | | | | |
| Dealer stamp | | | | | Dealer stamp | | | | |
| Date: _____ Signed: _____ | | | | | Date: _____ Signed: _____ | | | | |
| Dealer stamp | | | | | Dealer stamp | | | | |
| Date: _____ Signed: _____ | | | | | Date: _____ Signed: _____ | | | | |

Specifications

| PARAMETER | Pearl |
|--------------------|--------------------------------|
| LENGTH | 40.5" (103cm) |
| REAR WIDTH | 22" (56cm) |
| MAX. USER WEIGHT | 300lbs/ 21st (136kg) |
| BATTERY PACK | 21 AH |
| MAX SAFE ANGLE | 8° (at max user weight) |
| TURN RADIUS | 46" (117cm)" |
| SEAT - BASE HEIGHT | 12" - 17" (30cm - 43cm) |
| MAX SPEED | 4 mph (6 kph) |
| WHEEL SIZE FRONT | 7.5" (19cm) |
| WHEEL SIZE REAR | 8.5" (21.5cm) |
| RANGE | 15m/24km |
| OVERALL WEIGHT | 114lbs (52kg) (inc. batteries) |
| HEAVIEST PART | 35lbs (16kg) |



Trouble Shooting Guide

| SYMPTOM | POSSIBLE CAUSE | SOLUTION |
|---|---|--|
| Shortened range | Batteries not charged for long enough | Charge batteries for eight hours or more |
| | Batteries weak and cannot hold charge | Replace battery pack |
| Battery pack not charging | Battery pack fault | Replace battery pack |
| | Charge fault | Replace charger |
| | Charger loom or plug damaged | Contact local mobility dealer |
| | Loose connection | Check plugs and looms |
| | No output from wall outlet | Try a wall socket in a different room |
| | Fuse in charger mains plug blown | Unplug from wall & change fuse |
| Battery charging current high | Button on battery pack has popped out | Switch off and press button back in |
| | Faulty batteries | Replace battery pack |
| Battery gauge shows empty after charging | Scooter switched on during charging | Turn scooter off |
| | See battery pack not charging | See battery pack not charging |
| No drive | Brake-release lever disengaged | Engage brake-release lever |
| | Flat batteries | Charge battery pack |
| | Scooter or battery pack not switched on | Ensure both are switched on |
| | Battery pack not engaged properly | Check battery pack is clipped into place |
| | Scooter in sleep mode | Turn key off and on again |
| | Charger plugged in | Unplug charger |
| | Button on battery pack popped out | Reset circuit-breaker button |
| | Disconnected loom or plugs | Check all plugs & looms |
| Motor runs irregularly and/or noisily | Control system fault | Contact dealer |
| | Electrical malfunction | Contact dealer |
| DO NOT ATTEMPT TO OPEN ANY PARTS OF THE SCOOTER CONTROL SYSTEM, BATTERY PACK, LOOMS, PLUGS OR BATTERY CHARGER. THE CONTROL SYSTEM IS SAFETY CRITICAL AND THERE ARE NO USER SERVICEABLE PARTS | | |

Notes

Notes



Sunrise Medical Limited

Sunrise Business Park, High Street, Wollaston, West Midlands
DY8 4PS England

Tel 01384 44 66 88 Fax 01384 44 66 99

E-Mail: sunmail@sunmed.co.uk

www.sunrisemedical.com

Iss 5
07 04 2010

